

TRUCKS AND BUSES



PROFITABLE FOR LIFE.

Eicher Pro 6028
The 28 Tonne GVW Truck



EUTECH6

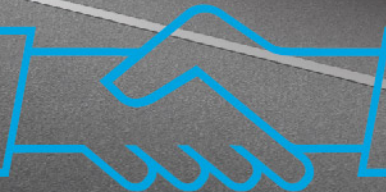

EUTECH 6

Eicher is creating a new benchmark in the Indian commercial vehicle industry, with a revolutionary BSVI solution that combines global technology with innovative support services. This solution doesn't just make your vehicle BSVI compliant but ensures higher productivity of the truck and profitability of your business.



Euro VI Expertise for 6 years

VECV has been manufacturing and supplying base engines to the Volvo Group since 2013. Over 1,00,000 Euro VI base engines supplied, operating in 41 countries. First to roll out BS VI CV range in India, incorporating expertise of Euro VI technology.



Efficient EATS and engine technology

Best fluid economy: Lower fuel consumption + DEF consumption combined. Reliable EATS + engine technology tested for over 56,00,000 km. Vanadium based SCR for high reliability & low maintenance.



Enhanced UPTIME

Eicher Uptime Centre for 24x7 support by specialists. GPS enabled service vans just a phone call away. Remote diagnostics for quick repair of BS VI vehicles.

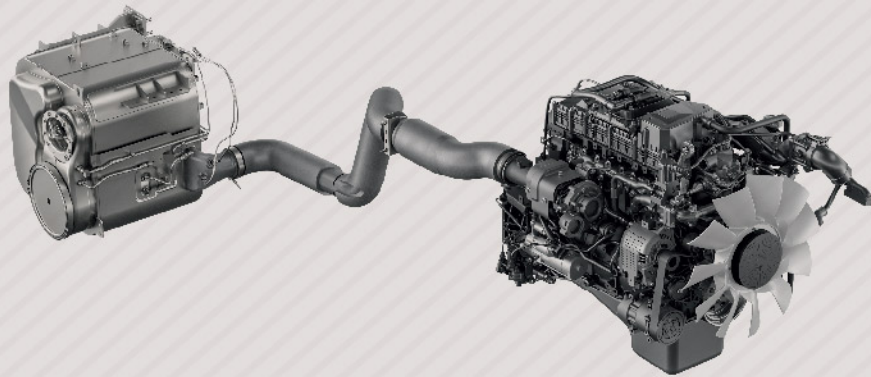

COMPACT BOX TYPE EATS FOR EFFICIENT THERMAL MANAGEMENT



The new Eicher Pro 6028 is the 28 tonne rigid haulage truck, powered with the proven VEDX5 engine delivering the best power and torque combination in its segment. It offers best-in-class fuel efficiency, maximum payload and optimized performance making Eicher Pro 6028 *Profitable for Life*.



More Km per Litre.

The new Eicher Pro 6028 is designed to deliver best-in-class fuel efficiency thereby reducing the overall operational costs and increasing profitability. The proven **VEDX5 engine** clubbed with Volvo Group's EMS, delivers **high peak torque over a wide range of rpm**, thereby resulting in more trips with lesser fuel consumption.

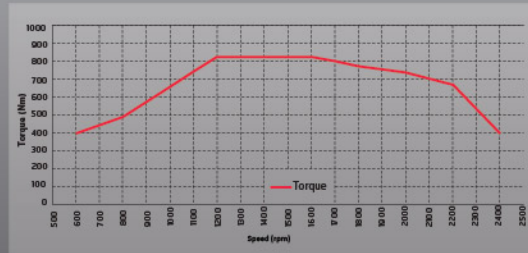
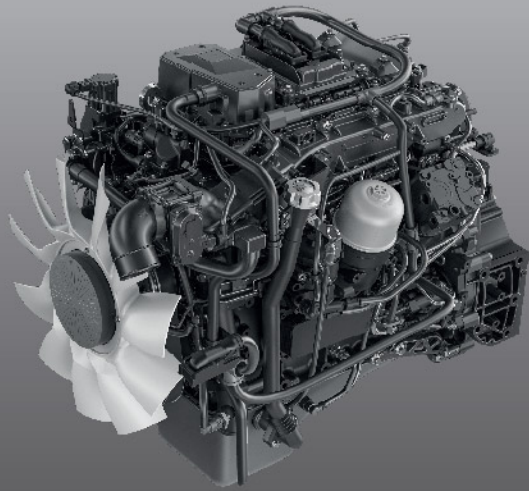

More Trips. Extra Miles.

Robust, rigorously tested and **optimized driveline** delivers more power and higher torque which enables higher productivity. **Quick gear shifts**, minimal RPM and torque disruptions enable better pick up. High torque to weight ratio ensures **outstanding gradeability**. All this together leads to **faster turnaround** and more trips.

- » High power to weight ratio for increased load pulling ability.
- » Modular DOMEX chassis for high tensile strength.
- » Parabolic suspension with Anti Roll Bar at front for better vehicle stability at sharp turns.
- » Slipper suspension at rear for low maintenance & better load carrying capacity.
- » Ergonomically designed cabin for increased driver productivity.

Parabolic suspension

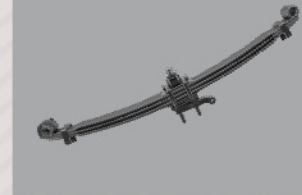

Slipper suspension

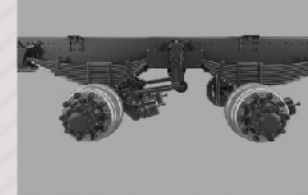

M Booster+



FIE system

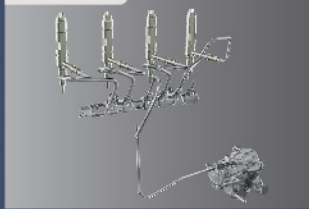

Volvo Group's EMS



ESS compressor

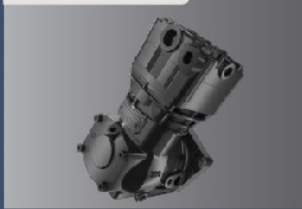

- » Proven VEDX5 CRS Engine- 210HP @2200 rpm.
- » Flat torque delivery of 825 Nm over wide rpm range (1200-1600 rpm).
- » **M Booster+** to optimize acceleration and maximize fuel efficiency.
- » First in industry **Fuel coaching** providing real time guidance for improved driver efficiency and fuel economics.
- » Energy saving components like Viscotronic fan & ESS compressor.

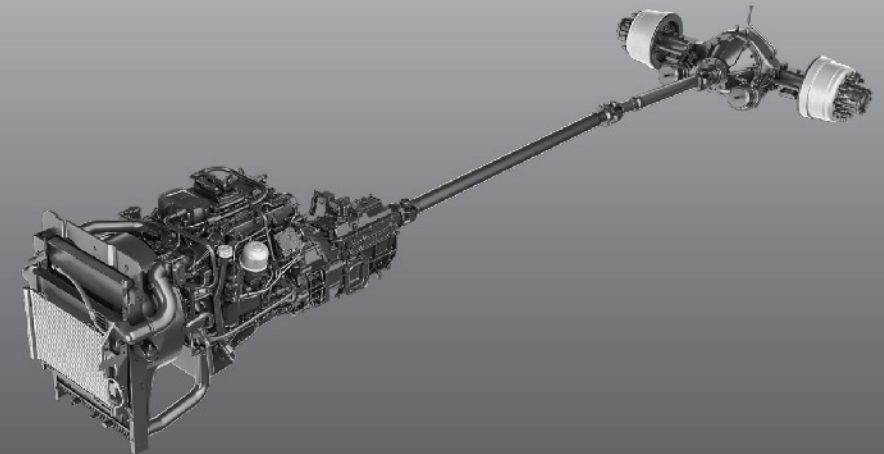

Superior Uptime.

Higher strength and lower weight composite material derive **maximum component life** ensuring truck is on road and available to haul always. With **the fully equipped Eicher Service Network**, preventive maintenance of the truck is ensured thus delivering superior uptime.



On Board Diagnostics



ET90 6 Speed Gearbox

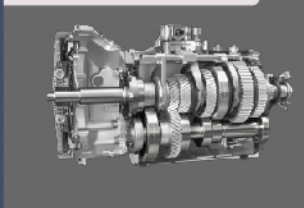

Bigger Crown Wheel

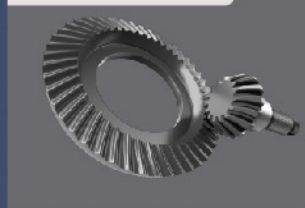

- » Advance on-Board Diagnostics system that displays fault indicators in the form of visual signals, messages and alarms.
- » Engine Protection System ensuring 4-way protection.
- » Exhaust brake to prevent engine over-running.
- » Longer and synchronized service intervals.

More Comfort. Longer Drives.

Pro 6028 Cabin has been designed keeping in mind the long and tiring journeys, the drivers have to travel in. The **global cabin** provides a **comfortable workspace** that ensures they are not only comfortable, but also safe while on their long runs.

- » Sleeper cabin for better comfort (HVAC Optional) .
- » Meeting AIS 029 cabin strength test.
- » Dual-panel cabin for structural strength.
- » Intelligent Driver information system (IDIS) that provides truck operational parameters.
- » Tilt & telescopic power steering & 6 way adjustable seat for better driving posture.
- » Cruise control for fatigue-free driving experience.



Lifetime Support Solutions.

With our Lifetime Support Solutions, we ensure a seamless and hassle free experience from the time you consider buying an Eicher vehicle to the time you think of selling it. Our continuously improving and holistic services will ensure higher uptime and productivity for your BSVI vehicles.



Eicher has taken a step towards achieving Superior Uptime with a responsive attitude, that will set us apart and create a differentiated experience for our customer. With our new Uptime Center and Uptime Certified Workshops, we are now geared up with a proactive support system for diagnostic assistance with advanced diagnostic tools.



At Uptime Certified Workshops only
*T&C Apply

Model Eicher Pro 6028

GVW (kg)	28000				
Engine model	VEDX5 - BSVI				
Max power	210 HP @ 2200rpm				
Max torque	825 Nm @ 1200-1600 rpm				
Clutch diameter (mm)	395				
Gearbox	ET90S6, Manual				
Rear axle	Heavy Duty fully floating single reduction, 458 mm drive head				
FDR	4.8				
Chassis dimensions (mm)	300 x 76 x 6				
Brakes	Dual-circuit, full-air 'S' cam with ABS				
Front suspension	Parabolic				
Rear suspension	Semi-elliptic slipper				
Cabin	Sleeper cabin				
Steering	Tilt and telescopic power steering				
Tyres	Front: 295/90R20 Rear: 10R20				
Fuel tank (l)	350				
DEF Tank (l)	50				
Battery	24V				
Gradeability (%)	21				
Wheelbase (mm)	5350		6800		
Variants	CBC	CWC	HSD	CBC	CWC
Load body span (mm)	7317	7745	7336	9422	9850
Applications	Market load, Tankers, LPG cylinders, e-commerce, Parcel & logistics, FMCG, White goods				

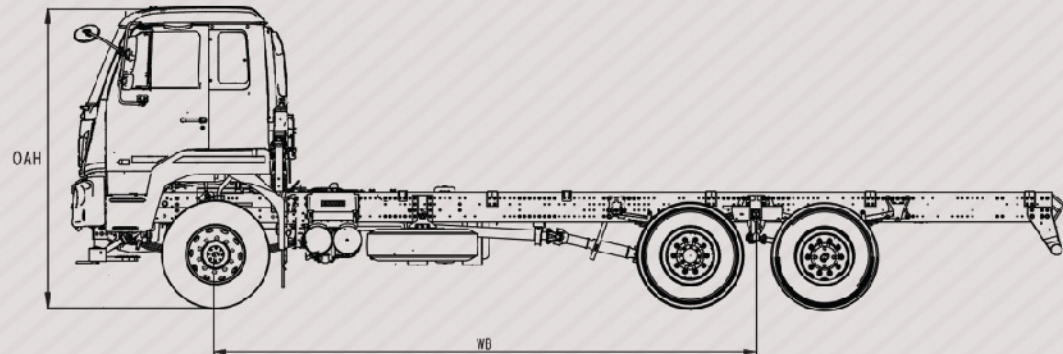
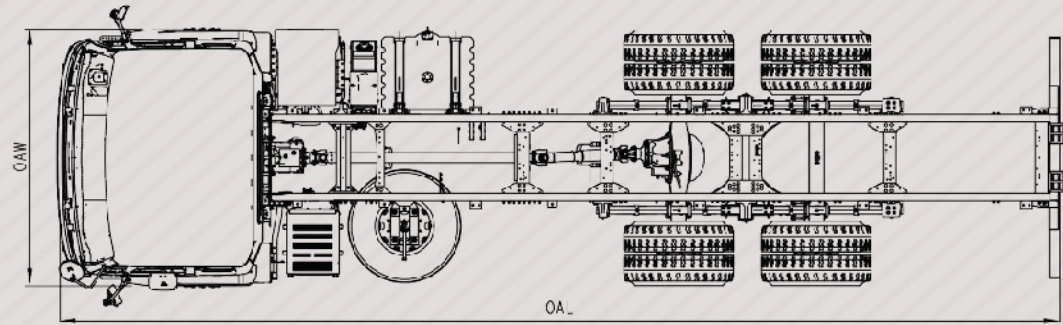

Vehicle model	Overall length (OAL) mm	Overall width (OAW) mm	Overall height (OAH) mm	Wheelbase (mm)
Pro 6028 CBC (7317mm)	9825	2481	2960	5350
Pro 6028 CBC (9422mm)	11880	2481	2960	6800



VE COMMERCIAL VEHICLES
A VOLVO GROUP AND EICHER MOTORS JOINT VENTURE
eichertrucksandbuses.com, Eicher Care: 1800 102 3531

VE COMMERCIAL VEHICLES LTD.
Registered Address – 3rd Floor Select Citywalk,
A -3 District Centre, Saket, New Delhi 110 107, India.
CIN – U74900DL2008PLC175032

CORPORATE ADDRESS
Eicher Trucks & Buses
#96, Sector – 32, Gurgaon
122001, Haryana, India.

Caution: *Do not weld or drill on chassis frame. *Accessories, colours and features shown in pictures or elsewhere may not constitute standard fitment. *Weight mentioned is for standard configuration with standard body sizes and will change due to optional fitments. *As a result of continuous research and innovation carried out, specifications are merely indicative and are subject to change without notice.